

# EM-IPCP5FE1-F14

## 5MP Fisheye Fixed Dome Network Camera



### Key Features



- High quality image with 5MP, 1/2.8"CMOS sensor
- 5MP (2592\*1944):@ 30/25fps;
- Ultra 265, H.265, H.264, MJPEG
- 120dB true WDR technology enables clear image in strong light scene
- Built-in 2 Mic, Supports the detection of sounds over longer distances
- Alarm:1 in/1 out, Audio: 1 in/1 out
- Smart IR, up to 10m (33ft) IR distance
- Supports 256 G Micro SD card
- IK10 vandal resistant
- IP66 protection
- Support PoE power supply

## Specifications

	EM-IPCP5FE1-F14				
Camera					
Image sensor	1/2.8", progressive scan, 5.0 megapixel, CMOS				
Minimum Illumination	Colour: 0.01 Lux (F2.0, AGC ON) 0 Lux with IR				
Day/Night	IR-cut filter for day & night function				
Shutter	Auto/Manual, shutter time: 1~1/100000 s				
WDR	120dB				
S/N	>55dB				
Lens					
Lens type	1.4mm@F2.0				
Angle of View	360°				
DORI					
DORI Distance	Lens	Detect (m)	Observe (m)	Recognize (m)	Identify (m)
	1.4mm	31.5	12.6	6.3	3.2
Illuminator					
IR Range	UP to 10m (33ft)				
wavelength	850nm				
IR On/Off Control	Auto/Manual				
Video					
Compression	Ultra 265, H.265, H.264, MJPEG				
H.264 code profile	Baseline profile, Main Profile, High Profile				
Frame Rate	Main Stream: 5MP (2592*1944): Max.30fps; Sub Stream: 1080P (1920*1080): Max.30fps; 720P (1280*720), Max 30fps; Third Stream: D1 (720*576), Max 30fps; 640*360,Max 30fps; 2CIF(704*288), Max 30fps; CIF(352*288), Max 30fps;				
Video Bit Rate	128 Kbps~16 Mbps				
U-code	Support				
ROI	Up to 8 areas				
Video Stream	Triple streams				
OSD	Up to 8 OSDs				
Privacy Mask	Up to 4 areas				
Image					
White Balance	Auto/Outdoor/Fine Tune/Sodium Lamp/Locked/Auto2				
Image Setting	Image rotation, brightness, saturation, contrast, sharpness, gain adjustable by web browser				
Digital noise reduction	2D/3D DNR				
Smart IR	Support				
Flip	Normal/Flip Vertical/ Flip Horizontal/180°				
Dewarping	N/A				
HLC	N/A				
BLC	Support				
Defog	Digital Defog				
Audio					

Audio Compression	G.711
Audio Bitrate	64 Kbps
Two-way audio	Supported
Suppression	Supported
Sampling Rate	8 KHZ
<b>Storage</b>	
Edge Storage	Micro SD, up to 256GB
Network Storage	ANR, NAS(NFS)
<b>Network</b>	
Protocols	IPv4, IGMP, ICMP, ARP, TCP, UDP, DHCP, PPPoE, RTP, RTSP, RTCP, DNS, DDNS, NTP, FTP, UPnP, HTTP, HTTPS, SMTP, 802.1x, SNMP, QoS, RTMP, SSH
Compatible Integration	ONVIF (Profile S, Profile G, Profile T), API,SDK
User/Host	Up to 32 users. 2 user levels: administrator and common user
Security	Password protection, Strong password, HTTPS encryption, Export operation logs, Basic and digest authentication for RTSP, Digest authentication for HTTP, TLS 1.2, WSSE and digest authentication for ONVIF
Client	EZStation EZView EZLive
Web Browser	Plug-in required live view: IE9+, Chrome 41 and below, Firefox 52 and below
	Plug-in free live view: Chrome 57.0+, Firefox 58.0+, Edge 16+
<b>Live View Display</b>	
Mount Type	Support table, wall, and ceiling
Decoding Mode	Support software decoding
Display Mode	11 display modes in total Software decoding: Ceiling mount: fisheye view, 360°Panoramic+1PTZ, 180°Panoramic, Fisheye+3PTZ, Fisheye+4PTZ, 360°Panoramic+6PTZ, Fisheye+8PTZ Wall mount: fisheye view, Panoramic, Panoramic+3PTZ, Panoramic+4PTZ, Panoramic+8PTZ Table mount: fisheye view, 360°Panoramic+1PTZ, 180°Panoramic, Fisheye+3PTZ, Fisheye+4PTZ, 360°Panoramic+6PTZ, Fisheye+8PTZ
<b>Interface</b>	
Audio I/O	Input: impedance 35 kΩ; amplitude 2 V [p-p]
	Output: impedance 600 Ω; amplitude 2 V [p-p]
Alarm I/O	1/1
RS485	N/A
Built-in Mic	Supported 2
Built-in Speaker	N/A
WIFI	N/A
Network	1 RJ45 10M/100M Base-TX Auto-adaptive Ethernet
Video Output	N/A
<b>Certifications</b>	
EMC	FCC CFR 47 Part 15
	EN 55032:2015
	EN 55024:2010
	EN 61000-3-2:2014
	EN 61000-3-3-2013
Safety	IEC 62368-1

	EN 62368-1 UL 62368-1
Environment	CE-ROHS (2011/65/EU;(EU)2015/863); WEEE (2012/19/EU); REACH (Regulation (EC) No 1907/2006)
General	
Power	DC12V±25%,PoE (IEEE 802.3af)
	Power consumption: Max. 8.5W
Power Interface	Ø 5.5mm coaxial power plug
Dimensions (Φ × H)	Φ125 × 43.7 mm (Φ4.9" × 1.7")
Weight	0.36kg (0.79lb)
Material	Metal + Plastic
Working Environment	-30°C ~ 60°C (-22°F ~ 140°F), Humidity: ≤95% RH (non-condensing)
Storage Environment	-30°C ~ 60°C (-22°F ~ 140°F), Humidity: ≤95% RH (non-condensing)
surge protection	4KV
Reset Button	Supported
Protection	Ingression protection: IP66 Vandal resistant: IK10

## Dimensions

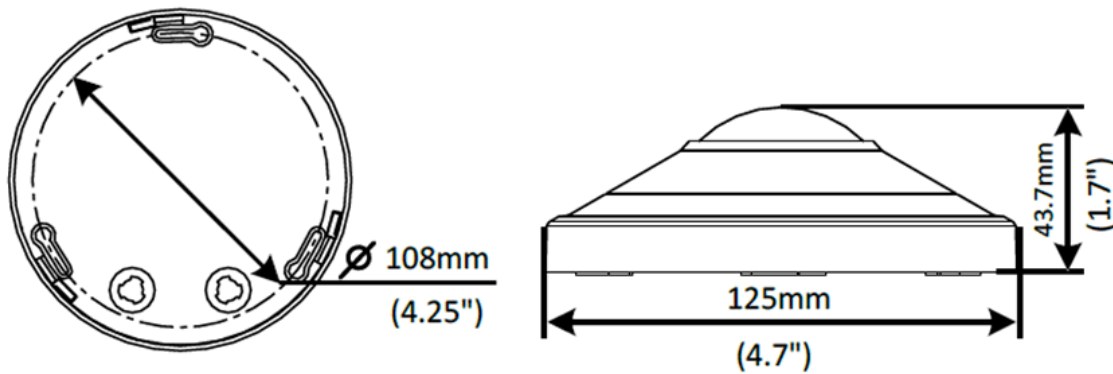

## Accessories



UN-TRJB03HIN



TR-A01-IN



UN-TRSE24IN



UN-TRSE24AIN

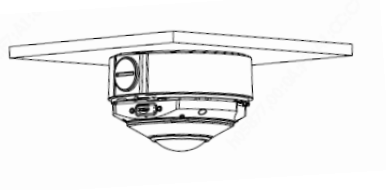
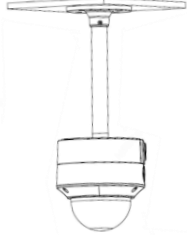

UN-TRCM24IN

Junction box	Indoor pendent mount
 A technical line drawing of the junction box. It shows a cylindrical component with a flat top and a slightly flared bottom. A circular detail on the side indicates a mounting or adjustment point.	 A technical line drawing of the indoor pendent mount. It shows the cylindrical body of the fixture with a long stem extending upwards to a flat, circular top. The drawing is shown from a perspective view.